

# motionoffice

## Wing Seat Assembly Instructions



### PARTS LIST:

- MBP1405
- MWNG14 (L&R Pair)
- MBACK06
- MCBASE06

### COMPONENTS LIST:

- 4 - Pins
- 4 - Plates
- 17 - Plate Screws
- 1 - Allen Key



# Wing Seat Assembly Instructions

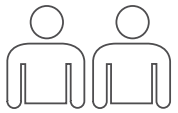

Recommended  
2-person Step

To prevent possible scratches or damage, assemble the product on a soft surface such as a blanket, carpet or packaging.

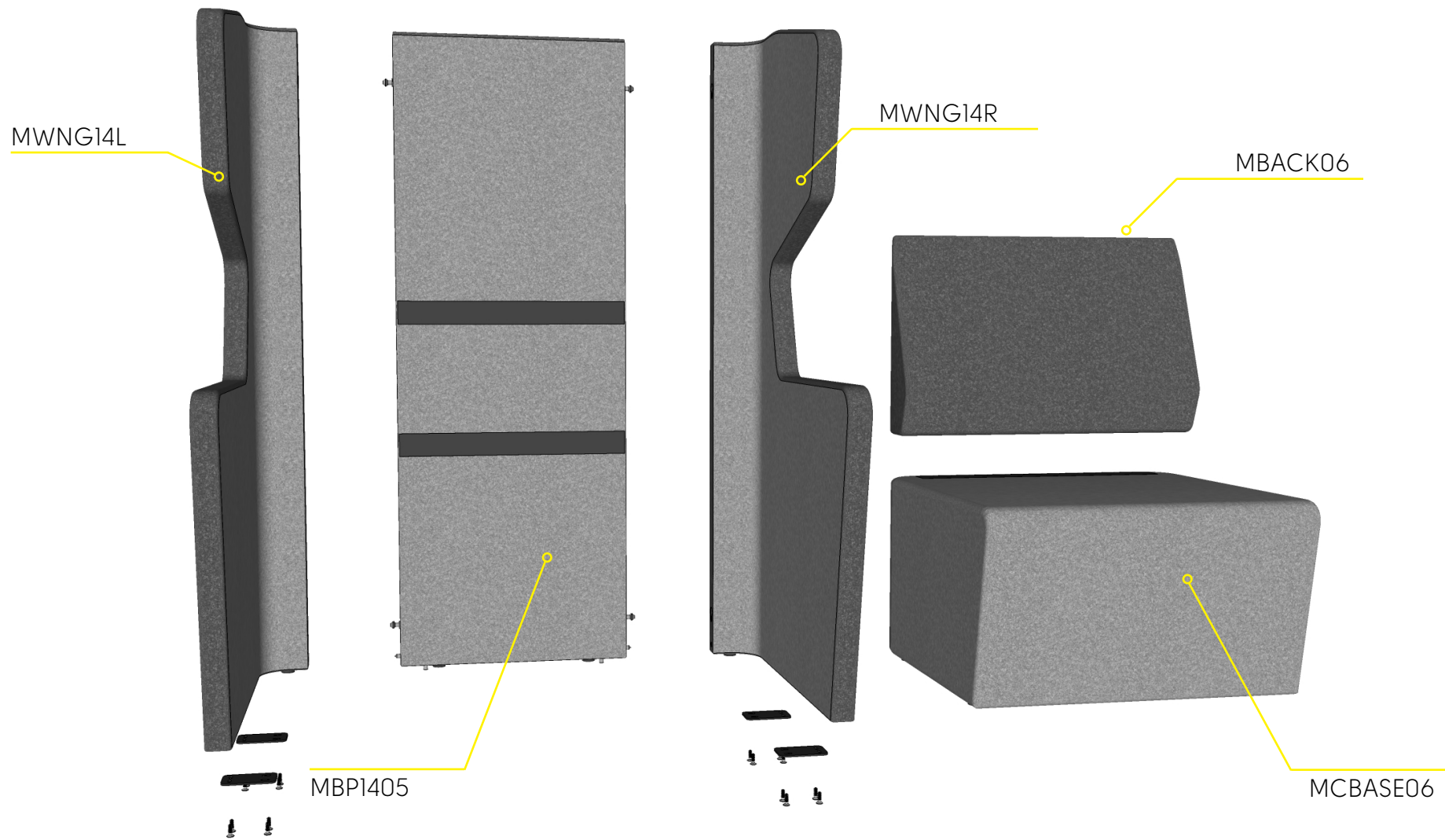

# Wing Seat Assembly Instructions

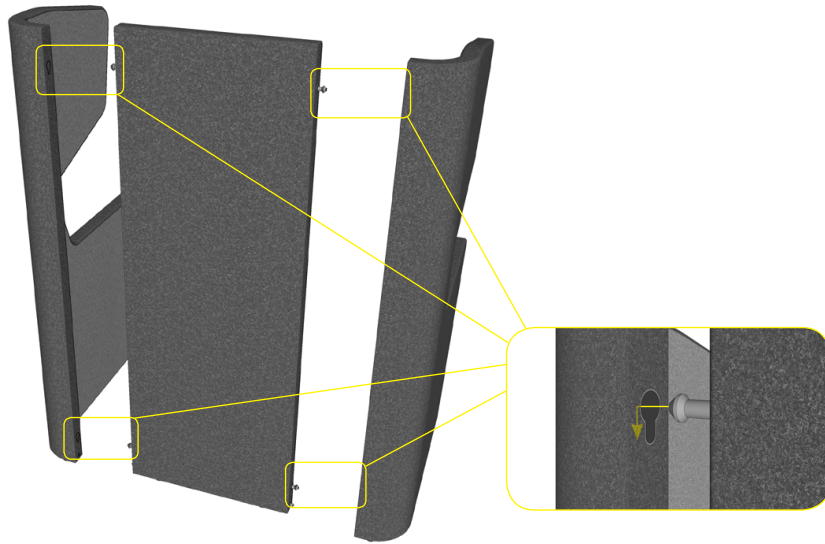

1 Insert Pins into keyholes, slide down until top is flush.

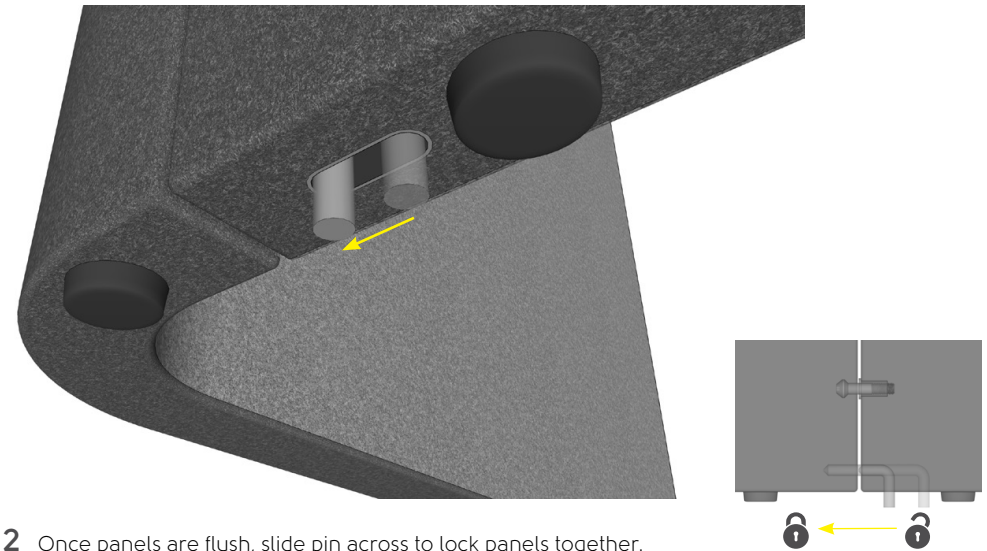

2 Once panels are flush, slide pin across to lock panels together.

3 Lie the panels on their back and place seat base inside, then screw plate to panels and seat base to fix firmly.

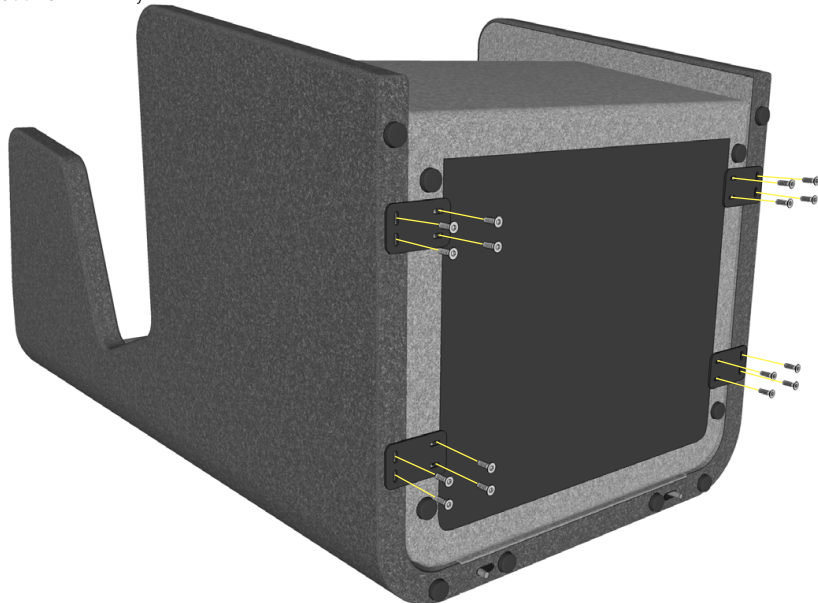

4 Locate the velcro strips on the backrest with those on the panels.

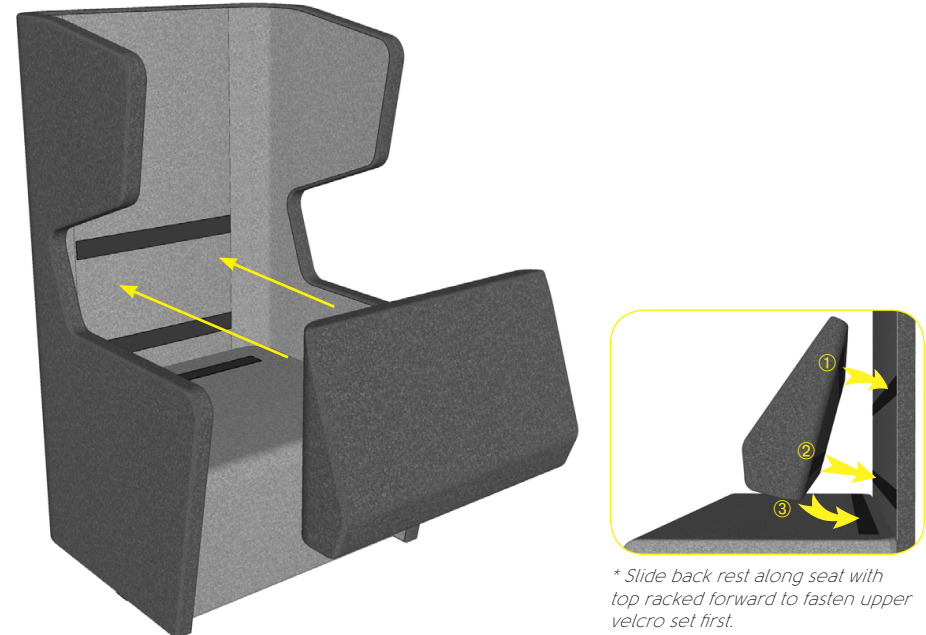

\* Slide back rest along seat with top racked forward to fasten upper velcro set first.