

WORKSPACE **48**

CAD QUICKSHIP MOTION | 2023



Delivery Times

48 hours

Warranty

Frame: 10 years

Fabric: Motion Felt 5 years

Freight

As per discount structure.

Assembly

Assembly is required for the majority of MotionOffice products and is not included in the product price.

Custom Items

30% deposit is required on custom orders. All custom orders must go through the MotionOffice Configurator at motionoffice.com or any custom items not shown in this document or on the configurator must go through a sign off process. The above delivery times may be subject to change based on fabric & order information and international holidays. Some custom fabrics according to manufacturers specifications may be unsuitable. Please check with your MotionOffice sales representative when placing your order.

Contents

Acoustics	4
Meeting	6
Expo	6
Arc	7
Loop	8
Wing	8
Tables	9
Backrest Covers	10
Throw Pillows	12
Accessories	13
Dimensions	14
Finish Options	16
Fabric Information	17
Freight	18
Terms & Conditions	19

Standard wall materials absorb 3%, MotionOffice has been tested and absorbs 76% of sound waves!

Imagine standing in the middle of a room with all concrete surfaces and one open window, and you blow a loud whistle. The sound that hits the open window passes right through. The sound that hits the concrete surfaces in the room begin to reflect back. The NRC (Noise Reduction Coefficient) of the open window would be 1.00 which is the absence of sound reflection. The NRC of concrete is .03, indicating that 97% of the noise that hits the concrete surfaces will reflect back off the surface. The NRC value of a surface simply denotes its ability to absorb vs reflect sound. The higher the NRC value, the stronger the sound absorption and the lower the sound reflection in the room.

MotionOffice panels have an NRC rating of 0.76 which means that 76% of the sound wave entering into the material will be captured and converted. MotionOffice dramatically contributes to reduction of noise bleed in open plan environments!

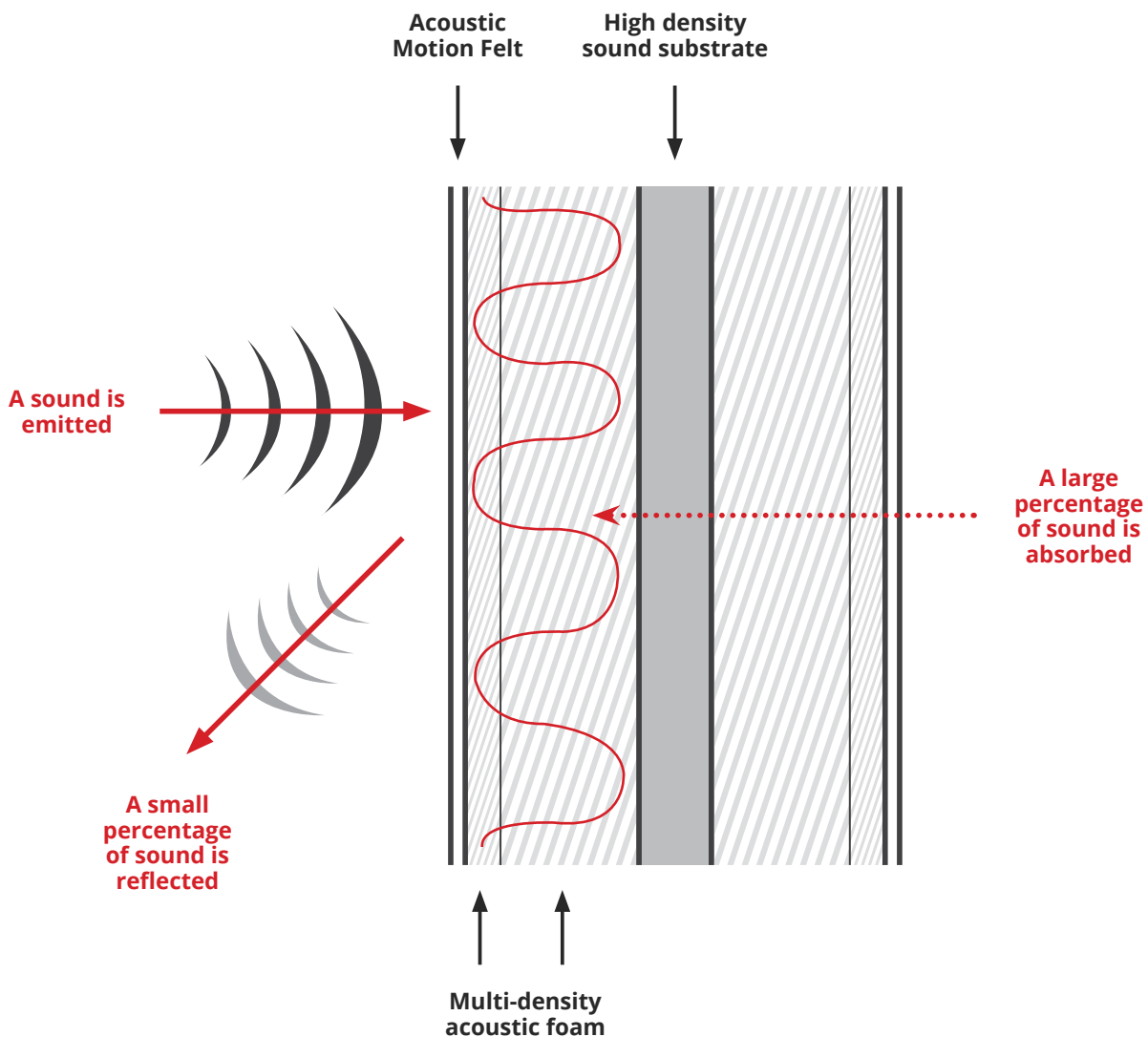

MotionOffice Acoustics - absorbs 76% of sound waves!

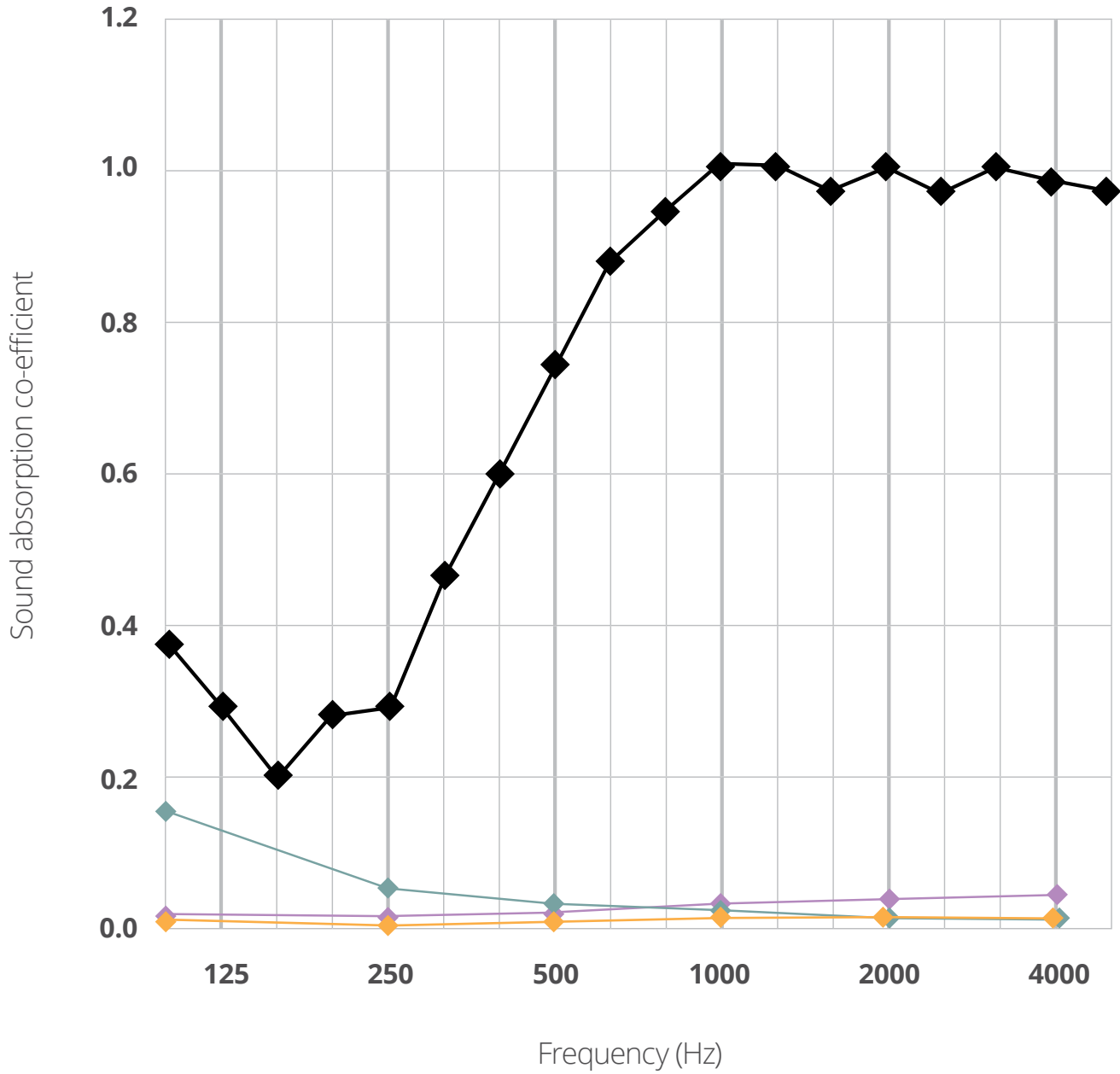

KEY:

- MotionOffice Materials
- Glass
- Concrete
- Gypsum Board (Gib Board)

Collaborative Motion



Backrest Covers

Additional backrest covers can be purchased separately. For code and color options see page 10.

Product	Description	Code	CAD
	<p>Motion Meeting Includes Motion Meeting Table White LPL Worksurface</p>	MCPMT4CLST/W	13517



Product	Description	Code	CAD
	<p>Motion Expo White LPL Worksurface</p>	MEXPO5CLST/W	19126



Shown with optional Motion Round Table, see page 9.

Product	Description	Code	CAD
	<p>Motion Arc 3 Includes 3x Motion Loop - Curved 60° Outer Back</p>	MARC3/CLST	7827
	<p>Motion Arc 4 Includes 4x Motion Loop - Curved 60° Outer Back</p>	MARC4/CLST	10433
	<p>Motion Arc 5 Includes 5x Motion Loop - Curved 60° Outer Back</p>	MARC5/CLST	13038







Backrest Covers
Additional backrest covers can be purchased separately. For code and color options see page 10.

Product	Description	Code	CAD
	<p>Motion Wing 1</p>	MWNG1/CLST	3385

Flexible Motion



Product	Description	Code	CAD
	Motion Loop - Straight Includes Backrest	MLPS7B/CLST	1522
	Motion Loop - Curved 60° Includes Outside Backrest	MLPC60BO/CLST	2606
	Motion Loop - Curved 60° Includes Inside Backrest	MLPC60BI/CLST	2412
	Motion Loop - Curved 90° Includes Outside Backrest	MLPC90BO/CLST	4191

Otto







Product	Description	Code	CAD
	Ottoman Includes casters	MOSTOOL_#	696

- Select fabric for Ottoman cover









Motion Felt **AS** **ST** **CL** **DB** **IC** **EM** **BB** **AV** **SO** **CR**

Tables











Product	Description	Code	CAD
	Motion Coffee Table - Straight White LPL Worksurface Black Frame	MST75B/W	328
	Motion Coffee Table - Curved White LPL Worksurface Black Frame	MCR60B/W	711
	Motion Tablet Table White LPL Worksurface Black Frame	MTABTB/W	223
	Motion Round Table - Coffee Height White LPL Worksurface Black Frame - 18" high / 41.3" diameter	MRT46B/W	633
	Motion Round Table - Sit Height White LPL Worksurface Black Frame - 28.7" high / 41.3" diameter	MRT73B/W	639
	Motion Round Table - Stand Height White LPL Worksurface Black Frame - 41.3" high / 41.3" diameter	MRT105B/W	646









Backrest Covers - Wing 1

Product	Description	Code	CAD
	Motion Backrest Cover 25.6" - Ash Grey Suitable for Motion Wing	MBACK06COV/AS	179
	Motion Backrest Cover 25.6" - Deep Blue Suitable for Motion Wing	MBACK06COV/DB	179
	Motion Backrest Cover 25.6" - Ice Blue Suitable for Motion Wing	MBACK06COV/IC	179
	Motion Backrest Cover 25.6" - Emerald Green Suitable for Motion Wing	MBACK06COV/EM	179
	Motion Backrest Cover 25.6" - Bumblebee Yellow Suitable for Motion Wing	MBACK06COV/BB	179
	Motion Backrest Cover 25.6" - Avocado Green Suitable for Motion Wing	MBACK06COV/AV	179
	Motion Backrest Cover 25.6" - Sunset Orange Suitable for Motion Wing	MBACK06COV/SO	179
	Motion Backrest Cover 25.6" - Chilli Red Suitable for Motion Wing	MBACK06COV/CR	179



Backrest Covers - Meeting

Product	Description	Code	CAD
	Motion Backrest Cover 55.1" - Ash Grey Suitable for Motion Meeting	MBACK14COV/AS	287
	Motion Backrest Cover 55.1" - Deep Blue Suitable for Motion Meeting	MBACK14COV/DB	287
	Motion Backrest Cover 55.1" - Ice Blue Suitable for Motion Meeting	MBACK14COV/IC	287
	Motion Backrest Cover 55.1" - Emerald Green Suitable for Motion Meeting	MBACK14COV/EM	287
	Motion Backrest Cover 55.1" - Bumblebee Yellow Suitable for Motion Meeting	MBACK14COV/BB	287
	Motion Backrest Cover 55.1" - Avocado Green Suitable for Motion Meeting	MBACK14COV/AV	287
	Motion Backrest Cover 55.1" - Sunset Orange Suitable for Motion Meeting	MBACK14COV/SO	287
	Motion Backrest Cover 55.1" - Chilli Red Suitable for Motion Meeting	MBACK14COV/CR	287

Throw Pillows

Product	Description	Code	CAD
	Motion Throw Pillow - Raw <i>*Must order with a throw pillow cover below</i>	MTPILLOW	72
	Motion Throw Pillow Cover - Ash Grey Cover Only	MTPILLOWCOV/AS	101
	Motion Throw Pillow Cover - Deep Blue Cover Only	MTPILLOWCOV/DB	101
	Motion Throw Pillow Cover - Ice Blue Cover Only	MTPILLOWCOV/IC	101
	Motion Throw Pillow Cover - Emerald Green Cover Only	MTPILLOWCOV/EM	101
	Motion Throw Pillow Cover - Bumblebee Yellow Cover Only	MTPILLOWCOV/BB	101
	Motion Throw Pillow Cover - Avocado Green Cover Only	MTPILLOWCOV/AV	101
	Motion Throw Pillow Cover - Sunset Orange Cover Only	MTPILLOWCOV/SO	101
	Motion Throw Pillow Cover - Chilli Red Cover Only	MTPILLOWCOV/CR	101

Accessories

Product	Description	Code	CAD
	Monitor Bracket Black Powdercoat	MMBRAC/B	138
	Bag/Coat Hook Black Powdercoat	MHOOK/B	22
	Name Plate Black Powdercoat	MNAME/B	25

Product Dimensions

Motion Meeting

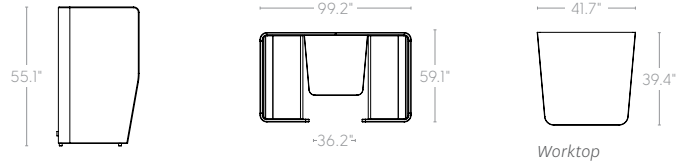

Motion Wing

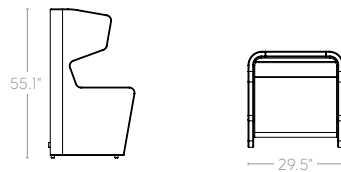

Motion Loop



Straight



60° Outer

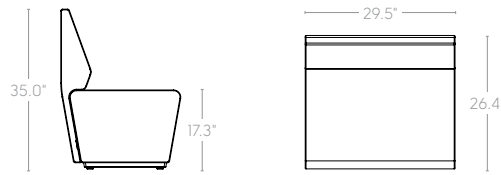

60° Inner



90° Outer

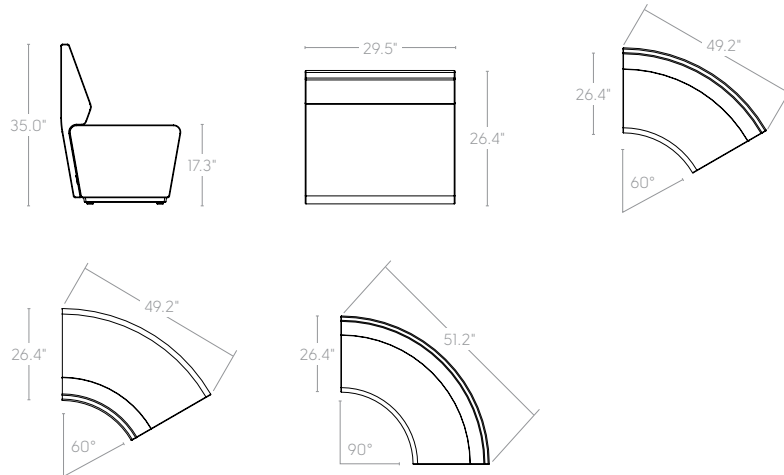

Motion Expo



Worktop Depth: 13.8"

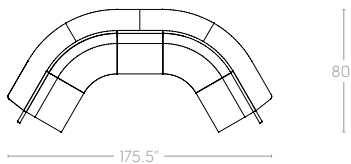

Motion Arc

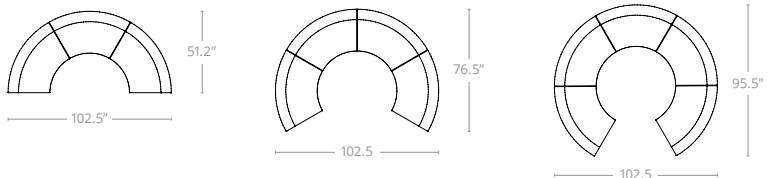

Motion Coffee Table Straight

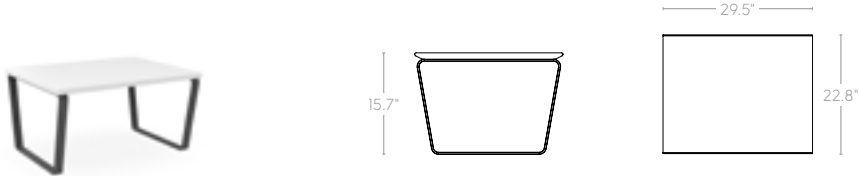

Motion Coffee Table Curved

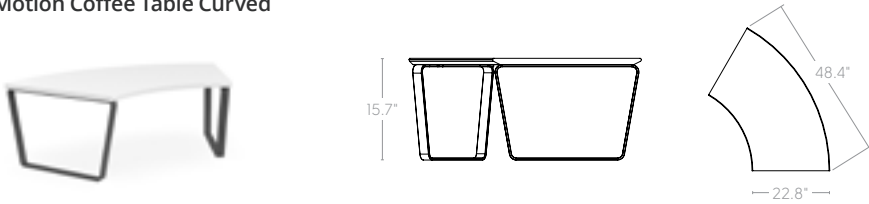

Motion Tablet Table

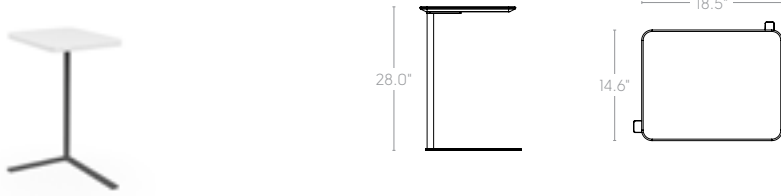

Motion Round Table

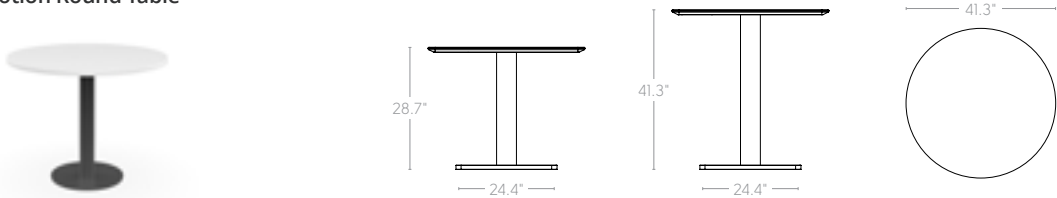

Motion Felt Colors

Stock Finishes

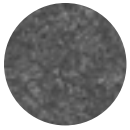

MFST Stone Grey

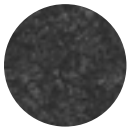

MFCL Charcoal Grey

Upgrade Finishes (Applies to Meeting and Wing 1 seatbacks, Throw Pillows only)

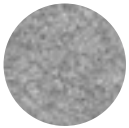

MFAS Ash Grey



MFBB Bumblebee Yellow

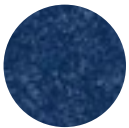

MFDB Deep Blue



MFAV Avocado Green



MFIC Ice Blue



MFSO Sunset Orange

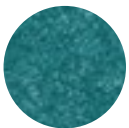

MFEM Emerald Green



MFRC Chilli Red

Fabric Information

Motion Felt is a wool blend textile with a soft hand and contemporary color-ways that will add a subtle, elegant distinction to larger, upholstered furniture items.

Motion Felt is yarn dyed and has been milled to give it a direction-less felted appearance. The milling process also increases the inherent durability and water repellent properties, which along with the natural flame resistant properties of wool, makes this fabric very suitable for heavy commercial use.

Technical Specifications

Type:	Upholstery
Composition:	50% Wool 50% Polyester
Weight:	750g/lin.m
Roll Width:	150cm
Repeat:	None
Abrasion:	100,000 rubs (Martindale)
Pilling:	4-5, BS EN ISO 12945-2:2000
Light Fastness:	4-5, BS EN ISO 105-B02
Flammability:	BS EN 1021.1 (cigarette) BS EN 1021.2 (match) CAL TB 117-2013
Color Matching:	Batch to batch variations in color may occur within commercial tolerances

Maintenance & Cleaning

Wool is naturally anti-static and water repellent making it less likely to attract dirt and absorb spillages. It is important to keep the fabric clean as this will extend the life of the fabric and preserve its fire retardant properties. Frequent (weekly) vacuuming on low suction is advised to remove dust and loose soiling. Under normal commercial use we recommend cleaning 1-3 times yearly by a professional dry cleaning service. It is important to protect the fabric from direct and refracted sunlight as this will ensure that the fabric retains its original color.

Spot Cleaning

Soiling should be acted on immediately to prevent lasting damage to the fabric. We always recommend testing stain removal detergents and solvents on an inconspicuous area first.

- Immediately absorb any liquids with an absorbent cloth.
- Scrape off any solidified material with a spoon.
- Remove loose material with a vacuum cleaner on low power.
- Wipe clean with a damp cloth using pH-neutral upholstery shampoo (follow directions on packaging). Do not scrub or use a stiff brush.
- Use clean water without any cleaning product for the final clean.
- Do not use dish washing or laundry detergents. Do not use detergents, bleach, ammonia or soap intended for hard surfaces.
- Dry with a clean white cloth using a circular dabbing motion to avoid edge marks. Use of hair dryer may also help avoid edge marks.
- Allow to dry thoroughly before reusing.

This is intended as a guide only. We recommend consultation with a fabric care professional.

Environmental

As a caring, corporate citizen, we support the responsible stewardship of the earth, its inhabitants and its resources.

Our fabrics are designed and made to last, and in their manufacture, use and disposal, embody the environmental principles of Reduce, Reuse & Recycle.

Fire retardants are bromide free.

Dyes are free from heavy metals.

Dealer Freight Schedule

ZONE 1 - Transit time: 1-3days	ZONE 2 - Transit time: 3-4days	ZONE 3 - Transit time: 3-5days	ZONE 4 - Transit time: 3-5 days	ZONE 5 - Transit time: 4-8 days
Minimum - \$125	Minimum - \$195	Minimum - \$195	Minimum - \$175	Minimum - \$205
\$0 - \$5,000: 6% of net	\$0 - \$5,000: 14% of net	\$0 - \$5,000: 17% of net	\$0 - \$5,000: 12% of net	\$0 - \$5,000: 18% of net
\$5,000 - \$10,000: 4% of net	\$5,000 - \$10,000: 12% of net	\$5,000 - \$10,000: 15% of net	\$5,000 - \$10,000: 11% of net	\$5,000 - \$10,000: 16% of net
\$10,000 - \$30,000: 3% of net	\$10,000 - \$30,000: 8% of net	\$10,000 - \$30,000: 10% of net	\$10,000 - \$30,000: 10% of net	\$10,000 - \$30,000: 11% of net
\$30,000 - \$100,000: 2% of net	\$30,000 - \$100,000: 7% of net	\$30,000 - \$100,000: 9% of net	\$30,000 - \$100,000: 9% of net	\$30,000 - \$100,000: 10% of net
\$100,000 +: Free	\$100,000 +: 3% of net	\$100,000 +: 5% of net	\$100,000 +: 1% of net	\$100,000 +: 5% of net

Quebec	Manitoba	Alberta	Prince Edward Island	Newfoundland & Labrador
Ontario	Saskatchewan	British Columbia	Nova Scotia	
*Freight free on orders over \$3,000			New Brunswick	
shipping to GTA and London Area*				

- Price ranges are shown as NET prices
- Modulus conference tables may have an additional \$100 freight charge. Please request freight quote per order
- Freight structures are based only on stock draw projects; container projects are quoted separately
- Freight schedules are subject to change every six months
- Freight rates are applicable to carriers and transit times selected by WORKSPACE48. Special requests may result in additional charges
- Freight rates are to metropolitan areas; shipments to all other areas may have additional charges
- Freight rates are per shipment, not per order. If two shipments are required, two freight charges will be applied.
- Workspace48 does not arrange shipping to the USA for orders sold through Canadian dealers.

Terms & Conditions

1. These terms and conditions shall apply to all sales of goods by Workspace48 Inc. No variation of any of these conditions shall be binding unless expressly agreed to by Workspace48 Inc. in writing.
2. All prices are exclusive of GST/HST unless otherwise stated.
3. All orders under \$3,000 net will be subject to a \$33 NET processing fee.
4. Payment in full shall be made to Workspace48 Inc. net 30 days on invoice. All orders over \$50,000 require a 35% deposit. Container payment terms are 30% deposit with order, 70% upon arrival of product. Workspace48 Inc. reserves the right to demand payment before that date or in advance and further reserves the right to specify in any quotation a requirement for a deposit to be paid before work shall commence. Interest shall be payable to Workspace48 Inc. on the Customer's overdue accounts at the rate of 18% per annum calculated on a daily basis to run from the due date for payment until receipt by Workspace48 Inc. of the full amount payable. The Customer shall pay all costs including any legal costs incurred in recovering overdue accounts.
5. We may suspend or terminate this agreement if at any time we consider the Customer's credit worthiness to be unsatisfactory for any reason or if the Customer is in default of any of its payment or other obligations hereunder. We shall not be responsible under any circumstances for any loss, damages, costs or expenses whatsoever caused in any way by the suspension or termination under this clause.
6. Goods returned for credit will only be accepted subject to Workspace48 Inc.'s prior agreement in writing with all freight charges prepaid by the Customer. Returned goods, if accepted by Workspace48 Inc., are subject to a minimum restocking fee of the greater of \$75 or 20% of the invoice price. Returned product will not be accepted if it has been removed from its original packaging and no credit will be issued for product returned damaged.
7. Prices are subject to variation without notice, and goods and services will be invoiced at prices current at the time of their provision unless otherwise agreed in writing.
8. Sales tax and any other taxes or duty on or in respect of the goods sold by Workspace48 Inc. imposed by any Provincial or Federal Government law shall be payable by the Customer, but if those taxes or duties by law are or become payable by Workspace48 Inc., the prices in respect of the goods shall be increased by the amount necessary to ensure that the net amount actually received by Workspace48 Inc. is as if those taxes or duties were not payable.
9. If the Customer is a limited liability company or a trust, then the director(s) and shareholder(s) of the company or the trustee(s) of the trust (as the case requires), hereby guarantee the performance of the Customer's obligations under this agreement and are personally liable to meet the Customer's obligations under this agreement in the event of the Customer's default. Those director(s) and shareholder(s) or trustee(s) also agree to indemnify Workspace48 Inc. and hold Workspace48 Inc. harmless for any losses Workspace48 Inc. sustains as a result of the Customer's act or

omission. A director, shareholder or trustee (as the case requires) must reimburse Workspace48 Inc. for all its losses caused by the Customer's act or omission within 21 days of Workspace Inc. making a demand for such reimbursement (time being of the essence). Any director, shareholder or trustee signing this agreement on behalf of the Customer also signs in a personal capacity for the purposes of the guarantee and indemnity contained in this clause.

10. The Customer warrants that such plans, specifications, measurements or information that have been supplied by the Customer at the time of commencing work on purpose built furniture are correct and can be relied upon. Once work has started the Customer may not vary or withdraw from this or any other agreement with Workspace48 Inc. unless with Workspace48 Inc.'s agreement in writing.
11. All warranties conditions and representations whether express or implied other than any express warranty stated by Workspace48 Inc. in writing are hereby expressly negated and excluded except in circumstances where Workspace48 Inc. is by law unable to exclude or limit its liability. Provided that where the Customer is a consumer for the purpose of the Trade Practices Act, but the goods or services are not of a kind ordinarily required for personal domestic or household use or consumption, the liability of Workspace48 Inc. shall be limited as determined by Workspace48 Inc. to anyone or more of the following:
 - a. The replacement of the goods or the supply of equivalent goods
 - b. The payment of the costs of replacing the goods or of acquiring equivalent goods
12. No claim of any nature whatsoever (other than relating to warranty) will be recognised unless made within 24 hours of delivery. All freight costs involved in returning goods must be paid by the Customer. A copy of the invoice evidencing sale to the Customer is to be included with the goods, and include photo's to clearly identify the issue concerned.
13. Subject to everything in these conditions Workspace48 Inc. makes no further condition, warranty or representation, whether express or implied, written or oral in respect of the goods or services.
14. Notwithstanding anything above Workspace48 Inc. shall not be liable for any consequential or indirect losses expenses or damages suffered by the Customer in consequence of any defect in materials or workmanship of the goods.
15. Claims for errors, short supply, or for goods arriving in a damaged condition shall be made within seven (7) days of the date of invoice, and the Customer shall refuse to sign any deliver docket where goods arrive in a damaged condition. Workspace48 Inc. must be notified of the claim within 24 hours and assigned a file number by Workspace48 Inc. or the claim will not be accepted. The Customer is deemed to have accepted the goods unless it makes a claim under this clause. The Customer acknowledges that a signed delivery docket signifies acceptance that the goods arrived in an undamaged state and Workspace48 Inc. shall not be liable to repair any damage in such cases. The Customer is responsible to file any claim resulting from Customers' carrier.
16. Risk in goods supplied under this agreement passes to the Customer upon delivery to the Customer or its agent or upon possession of the goods by the Customer or its agent, whichever is the earlier.
17. Workspace48 Inc. shall not be liable in any way whatsoever for any failure to deliver any order on time or for non-delivery or delay caused directly or indirectly by war, act of God, strike, lockout, riot, Government action or interference, fire, earthquake, material, shortage, late delivery by manufacturers, shipping or transport delay or any other cause beyond the reasonable control of Workspace48 Inc. The Customer shall be bound to accept and pay for goods delivered within a reasonable time after such cause for the failure or delay on the part of Workspace48 Inc. has ceased to operate.
18. To the fullest extent possible, ownership of any goods supplied by Workspace48 Inc. is retained by Workspace48 Inc. until payment in full is made for the goods supplied and for all other goods supplied by Workspace48 Inc. to the Customer. This clause creates a security interest under the Personal Property Securities Act 2009 in favour of Workspace48 Inc. in all present and after-acquired property supplied by Workspace48 Inc. to the Customer. Customers waive the right to be notified in writing of registration on the Personal Property Securities Register.
19. Workspace48 Inc., its servants or its agents may immediately without giving the Customer any notice or waiting any time, retake possession of the goods supplied or any other goods supplied by Workspace48 Inc. under any other arrangement under which title in those goods is still maintained by Workspace48 Inc.
20. The Customer gives Workspace48 Inc. authority for its servants and agents to enter and remain upon any land or premises where in Workspace48 Inc.'s opinion Workspace48 Inc.'s goods may be stored and take possession of the said goods.
21. Under no circumstances shall Workspace48 Inc. be liable for any damage, costs, losses or expenses arising on or resulting from such repossession.
22. The Customer shall hold the proceeds of sales of our goods arising in the normal course of trade, upon trust for Workspace48 Inc. and shall promptly account to Workspace48 Inc. for such proceeds or the amount of them necessary to pay all amounts due to Workspace48 Inc.
23. The failure on the part of Workspace48 Inc. to exercise and enforce any rights conferred by this agreement shall not be deemed to be a waiver of any such right nor operate so as to bar the exercise or enforcement thereof at any time or times thereafter.
24. All freight charges are as described in your company specific discount structure, unless otherwise specified on a project specific quotation.
25. Upon receipt of an approved credit application, orders can be placed in the following way; Phone: 416 441 9898; Email: Orders@workspace48.com. Phone orders are required to have final confirmation in writing. All orders will be acknowledged by email as final confirmation of your order, including net pricing and quantities. If in the unlikely event of low stock, you will be notified and alternative solutions advised.
26. In-stock items can be cancelled by the Customer in writing prior to dispatch, without any cancellation charge. Orders cancelled after shipping and before arrival to the Customer will be subject to a minimum handling fee of \$75 plus any applicable direct costs, payable by the Customer. Any custom built products are not able to be cancelled once the order has been acknowledged and entered into production.



Our Vision

**REVOLUTIONIZING THE WAY OFFICE
FURNITURE IS BOUGHT AND SOLD.**

WORKSPACE 

E info@workspace48.com | P 416 441 9898